

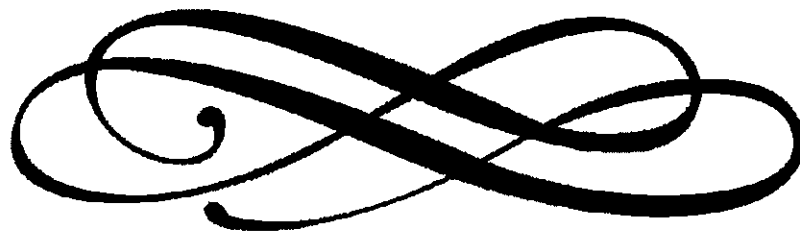

THE LODGE
at Mount Magazine

Wedding Guide



16878 HIGHWAY 309 SOUTH | PARIS | AR 72855
479 963 5100 | 877 665 6343 | fax 479 963 2202
www.mountmagazinestatepark.com

CONTENTS

Introduction.....	2
Staff Information	3
Function Space.....	4
Function Space Pricing.....	5
Lodge Room Rates.....	6
Cabin Rates.....	7
Pavilion and Overlooks.....	8
Rental Items	9
FAQ's	10-13
Helpful Hints.....	14-15
Catering Menu & Policies	16-31
<i>Policies</i>	16-19
<i>Baked Goods and Snacks</i>	20
<i>Beverages</i>	21
<i>Breakfast</i>	22
<i>Hors d'ouvres</i>	22-24
<i>Carving Stations</i>	25
<i>Luncheons</i>	25-26
<i>Plated Dinners</i>	27-29
<i>Buffets</i>	29-30
<i>Desserts</i>	30
<i>Children's Menu</i>	31
Alcohol.....	32-33
Saving the Date	34



THE LODGE
at Mount Magazine

Congratulations on your Engagement!

We want to thank you for your interest in The Lodge at Mount Magazine. We are very excited to show you what Mount Magazine State Park, Arkansas' highest peak, has to offer.

The Lodge at Mount Magazine is ideal for weddings, receptions, and rehearsal dinners. The setting is one of the most beautiful in the State. Our lodge accommodations include 60 guest rooms and 13 full-service cabins that all have a view to the South overlooking the beautiful Petit Jean River Valley.

Our banquet facility offers 3,840 square feet of space and can accommodate up to 200 guests. The banquet hall has the capability of being divided into three rooms of 1,280 square feet each. Two smaller meetings rooms have 880 square feet per room and include a hospitality service counter. The Lodge offers on-site catering and can prepare anything from full course dinners to light hors d'oeuvres. We can create a menu to suit your particular wedding style.

An ideal setting for your ceremony is The Terrace. The large stone terrace is located just off of the main lobby of the lodge. This location offers a gorgeous view of the Petit Jean River Valley and Blue Mountain Lake. The terrace can accommodate seating for approximately 200 people.

Located approximately 1 mile from The Lodge is Cameron's Bluff. This location offers dramatic views of the surrounding bluffs and the valley below. Stone steps and pillars create a rustic setting for an outdoor ceremony of approximately 50 guests. Our pavilion is the perfect place to hold a small, informal reception.

All of our sales, catering, and banquet staff are here to help you in any way we can. We encourage you to call for an appointment to ensure that you receive the best service possible. We can arrange a tour and/or meeting with one of our sales professionals to help you make this important decision.

GROUP SALES STAFF

Our sales, catering, and banquet staff are here to help you in any way we can. We encourage you to call for an appointment to ensure that you receive the best service possible. We can arrange a tour and/or a meeting with one of our sales professionals to help you make your decision and introduce you to The Lodge at Mount Magazine

Heidi Ryan

Director of Sales and Marketing

479-963-5240

heidi.ryan@arkansas.gov

Brandy Crandall

Assistant Director of Sales and Marketing

479-963-5241

brandy.crandall@arkansas.gov

or

call us toll-free at

1-877-MM-LODGE

(1-877-665-6343)

Our office hours are Monday – Saturday 8:00am – 5:00pm



BANQUET HALL & MEETING ROOMS

BANQUET HALL

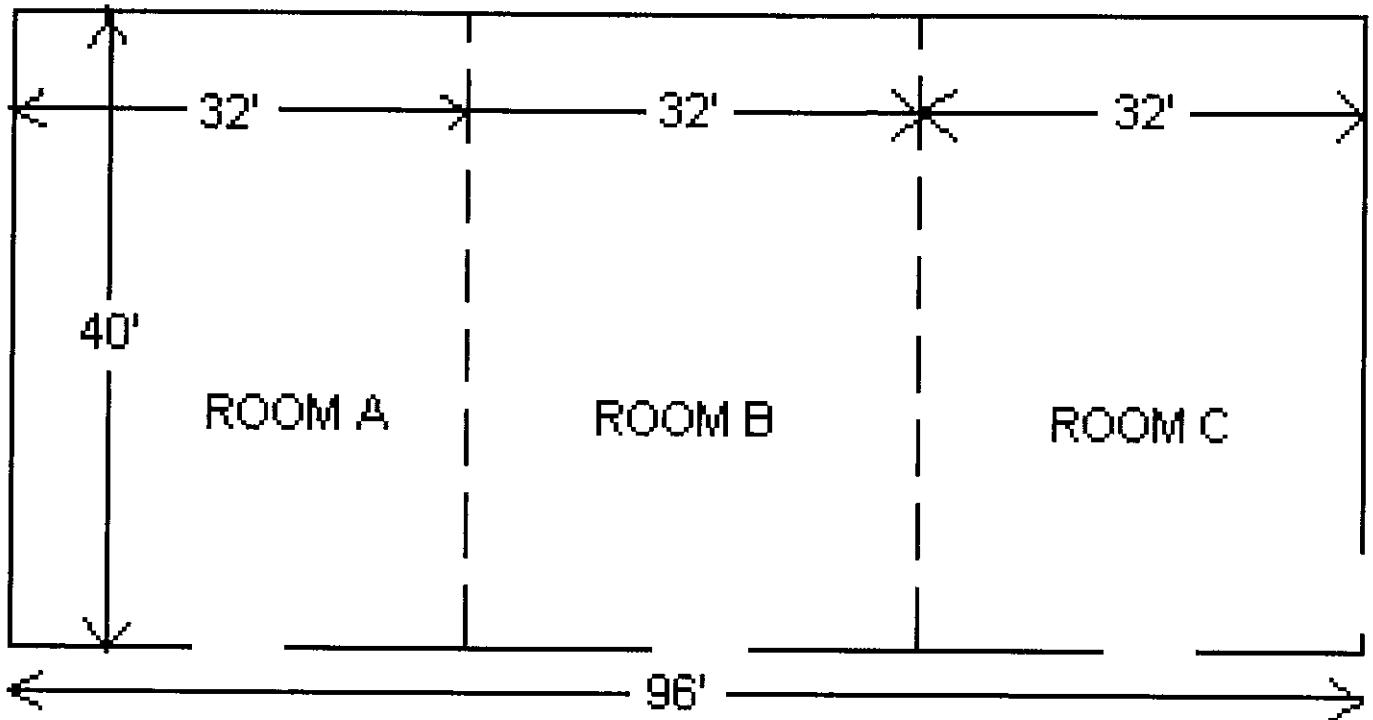

MEETING ROOMS

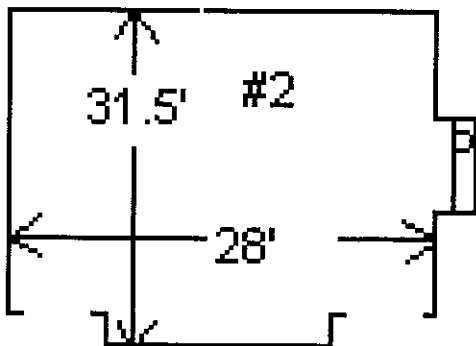
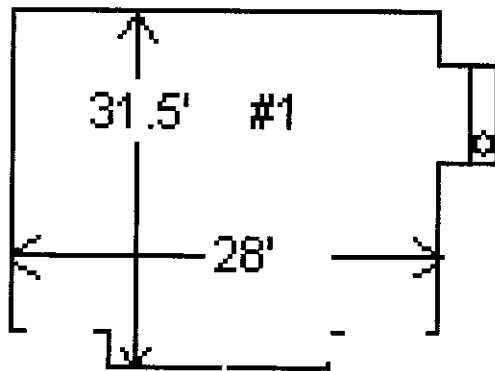

The Banquet Hall has 3,840 square feet of space with the capability to divide into three rooms of 1,280 square feet each. An Audio/Visual Presentation System is available in each banquet and meeting room. All visual media formats from computer to digital camera are displayable in large screen format from overhead projection systems. Wireless High-speed Internet access is available in the Banquet Hall, Meeting Rooms and most Public areas inside The Lodge.

BANQUET HALL & MEETING ROOMS

Number of Guestrooms or Cabins Rented

Banquet Hall or Meeting Room Price

Total Banquet Hall (3840sq. ft.):

No lodge rooms or cabins

1 to 20 rooms or cabins

21 to 40 rooms or cabins

41 or more rooms or cabins

\$600 per use

\$400 per use

\$200 per use

Complimentary

Individual Banquet Room (1280 sq. ft.):

No lodge rooms or cabins

1 to 14 rooms or cabins

15 to 30 rooms or cabins

31 plus rooms or cabins

\$210 per use

\$170 per use

\$90 per use

Complimentary

Meeting Room (880 sq. ft.):

No Lodge rooms or cabins

1 to 15 rooms or cabins

16 rooms or cabins

\$150 per use

\$75 per use

Complimentary

Terrace (4 hour rental)

\$600 per use

(no discount for rooms rented)



MOUNT MAGAZINE STATE PARK LODGE AND CABIN RATES 2012

<u>WEEKDAY</u> Sun-Thurs <i>(March 1 – November 30)</i>	<u>WEEKEND</u> Fri & Sat	<u>WINTER</u> Sun-Sat <i>(Dec 1 – Feb 28)</i>
QUEEN STANDARD ROOM (24 available) <i>Two queen beds, no balcony</i>		
\$117	\$147	\$100
QUEEN DELUXE ROOM (19 available) <i>Two queen beds, balcony</i>		
\$147	\$167	\$110
SINGLE KING (13 available) <i>King bed, Jacuzzi, balcony</i>		
\$157	\$177	\$130
HONEYMOON SUITE (4 available) <i>King bed, Jacuzzi, balcony, gas fireplace, kitchenette, sitting area and microwave</i>		
\$187	\$217	\$160

**** All lodge and cabin rates are per night****
Check in time 4:00pm – Checkout time 11:00am

- ** Wireless internet is available in all lodge rooms and cabins
- ** Prices reflect two people per room occupancy (Extra person over age 12 is \$10 daily charge)
- ** Lodge rooms are 100% smoke free and 100% pet free

MOUNT MAGAZINE STATE PARK LODGE AND CABIN RATES 2012

WEEKDAY

Sun-Thurs

(March 1 – November 30)

WEEKEND

Fri & Sat

WINTER

Sun-Sat

(Dec 1 – Feb 28)

1 BEDROOM CABIN (4 available)

King bed, full kitchen, full living room, Hot tub on the deck

\$215

\$275

\$190

1 BEDROOM PET FRIENDLY (1 available)

King bed, full kitchen, full living room, Hot tub on the deck

\$215

\$275

\$190

**** When reserving the Pet Friendly cabin (dog's only) you must provide current vaccination records. There is a \$40 charge per pet, limit 2****

2 BEDROOM CABIN (7 available)

King bed in each bedroom, full kitchen, full living room, Bathroom for each bedroom and hot tub on the deck

\$295

\$375

\$260

3 BEDROOM CABIN (1 available)

King bed in each bedroom, full kitchen, full living room, Bathroom for each bedroom and hot tub on the deck

\$395

\$455

\$340

**** All lodge and cabin rates are per night****

Check in time 4:00pm – Checkout time 11:00am

** Wireless internet is available in all lodge rooms and cabins

** Prices reflect two people per room occupancy (Extra person over age 12 is \$10 daily charge)

** Lodge rooms are 100% smoke free and 100% pet free

PAVILION & OVERLOOKS

Cameron Bluff Overlook provides breathtaking views for an outdoor wedding ceremony of approximately 50 guests. Visitors are welcome to use the overlook free of charge. However, reserving it assures that it will be available for your special occasion.

The park's modern rustic-style stone and wood beam **picnic pavilion** is excellent for wedding receptions. The open sides allow you to enjoy the outdoor atmosphere while still being protected in times of inclement weather. The inside of the pavilion measures 1,250 sq. ft. and has 10 moveable picnic tables. A large barbecue grill/fireplace is on the northwest side of the pavilion. For comfort and convenience, electrical outlets, ceiling fans, lights, water, and clean restrooms are located in, or adjacent to, the pavilion. The park visitor center is located directly across the street.

On the edge of Cameron Bluff looking west over the Arkansas River Valley is a 225- square-foot **gazebo**. Popular for small weddings the gazebo is also an excellent setting for enjoying the colorful sunsets as seen from the top of Mount Magazine. Visitors are welcome to use the gazebo free of charge. However, reserving it assures that it will be available for your special occasion.

Cameron Bluff Overlook	<i>\$70.00 per 2 hours</i>
Cameron Bluff Gazebo	<i>\$70.00 per 2 hours</i>
Pavilion.....	<i>\$45.00 8am-2pm</i>
	<i>\$45.00 4pm-10pm</i>
	<i>\$65.00 8am-10pm</i>

The Lodge does not provide set-up or catering services at these locations.

If you would like additional information or to book one of these areas, please contact the Visitor Center at 479-963-8502.

RENTAL ITEMS

The items listed below are available for an additional rental fee and are not included in the rental of the banquet facilities or terrace.

Dance Floor (18'x18')\$150.00
Brown Tablecloths\$8.00 per cloth
<i>(limited availability)</i>	
Floor Length White Tablecloths\$10.00 per cloth
<i>(limited availability)</i>	
White Cocktail Length Tablecloths\$4.00 per cloth
<i>(85" square White cocktail length cloths are included with food service)</i>	
Punch Fountain\$75.00 each
<i>(a minimum of 3 gallons of punch must be purchased for the fountain to operate properly)</i>	
Wireless Lapel Microphone\$25.00 each
Handheld Microphone with Stand\$25.00 each
Conference Phone\$25.00 each
Wireless Presenter with Laser Pointer\$20.00 each
Flip Chart with Markers\$25.00 each
Post-It Flip Chart with Markers\$30.00 each
Dry Erase Board with Markers\$25.00 each
Riser – 4'x8'x16"\$50.00 each
<i>(2 available)</i>	
Riser – 4'x8'x8"\$50.00 each
<i>(2 available)</i>	
White Outdoor Folding Chairs\$3.00 per chair
<i>(chairs for the terrace and patio must be rented from The Lodge, and cannot be brought in from an outside source.)</i>	
Serpentine Tables\$15.00 per table
<i>(5 available)</i>	

FREQUENTLY ASKED QUESTIONS

“What services does The Lodge provide for a wedding?”

The Lodge at Mount Magazine provides the venue, set-up, and food. We do not provide an on-site wedding coordinator; the guest is responsible for any decorating and/or organizing. There are no “wedding packages” available. You can build the event that you want.

“How many guests can I have at my event?”

The guest limit at The Lodge at Mount Magazine is 200. We cannot accommodate more than this. *If you are having a dance floor, buffet line, or other extras at your event, then the maximum number decreases.*

“What if my ceremony is scheduled for outside and it is raining?”

If you have rented the banquet hall for your wedding reception, the ceremony will be moved into the banquet hall. Since the hall will already be set up for the reception, we will pick a central area in the room for the ceremony, and your guests will sit at the reception tables. If the dance floor is rented, this is a great place for the ceremony, the rented white outdoor chairs must be used as they do not scratch the floor. The Hearth Room in the Lobby and the Restaurant are public areas, and cannot be reserved for an event in case of rain.

“What all is included with the rental of the Banquet Hall?”

The Banquet hall rental includes, glasses, silverware, plates, napkins, and white linens with foodservice; the set-up of the tables and chairs; the use of the banquet hall sound system, and cleanup after the event. Any decorations and clean-up of decorations is the responsibility of the guest.

“Is there a sound system outside on the terrace?”

There is not a sound system outside. There are electrical outlets, so guests can bring their own portable sound system. This is usually not necessary. A portable CD player is usually all that is needed for music. String instruments (acoustic guitar, violin, etc...) sound great on the terrace and do not require a sound system.

“Can we have music during the reception?”

Yes, you can have music. However, if you will have a deejay, a band, or music for dancing and entertainment, you will be required to rent the entire banquet hall, and cannot rent just one section. If you will be playing only soft background music, then it is acceptable to rent only a section of the banquet hall.

FREQUENTLY ASKED QUESTIONS

“What can we use for the Bride & Groom’s exit?”

Balloon releases, butterfly releases, and sparklers are not permitted due to Arkansas State Park and U.S. Forest Service Policies. You may throw birdseed or real flower petals (artificial petals are not permitted outside). However these items must be cleaned up by the group in a timely manner. Bubbles are permitted outside, but cannot be passed out to guests until they are outside as bubbles are not permitted in the banquet hall.

“Where will we have our rehearsal dinner?”

You have a couple of options for a rehearsal dinner. The first is to rent a banquet room for the night before the wedding, and order from our catering menu. Second is to rent our Pavilion and either have a cookout or have a private caterer. Another option is to have the rehearsal dinner off site. Finally, if there will be less than 25 people in attendance, you may have your rehearsal dinner in the Skycrest Restaurant.

However, please remember that *we do not reserve seating in the restaurant.* Your guests will either order from our restaurant menu, or if a buffet is available that evening, they may dine from the buffet. If dinner will be in the restaurant, all meals should be paid on one check. Remember – any outdoor areas may be booked by another group during your rehearsal time.

“What is provided at Cameron’s Bluff or the Pavilion”

The Lodge does not provide any services at the Overlooks or Pavilion for events. The rental fee ensures that the area is clean and ready for use. Any decorating, organizing, or catering is the responsibility of the guest. The pavilion has electricity and picnic tables. Any other items or chairs should be provided by the guest. Chairs for the overlook must be provided by the guest as well. The Lodge cannot rent our outdoor chairs at this location.

“Is there a place for the wedding party to get ready?”

The Lodge does not have a bridal room. You may get ready in your guestrooms, or you may rent a small meeting room for you and your party to use. It is always a good idea to bring extra mirrors if many are getting ready at the same time.

“Who will be there to help us on the day of the wedding?”

Our banquet, restaurant, and/or sales staff will be here on the day of the wedding. They are employees of The Lodge and should not take the place of a wedding planner. The wedding planning and coordinating is the responsibility of the wedding party.

FREQUENTLY ASKED QUESTIONS

“What can we use to decorate?”

You can use flowers, centerpieces, candles (must be contained to catch any dripping wax) columns, balloons, etc. We do not allow any decorations to be hung on the walls or from the ceilings. Items cannot be fixed to tables, chairs, or floors without permission. Fog machines, confetti, glitter, spray glitter, spray adhesive, popcorn, crepe paper, bubbles, silly string or sequins are also not allowed. On the terrace, if flower petals are dropped, they must be real petals, not artificial.

“When can we start decorating the banquet hall?”

If you rent the banquet hall for the day of the wedding, you may have access to decorate at 8:00 am that morning. This reservation is for the day of the wedding only, so you will not be allowed to decorate the night before. If you reserve the banquet hall for the day before the wedding as well, you may decorate at that time.

“What time do we have to be out of the Banquet Hall/Meeting Room?”

All events must end at midnight. All guests must leave at that time.

“May we bring our pets?”

Arkansas State Park policy does not allow any pets in The Lodge. This includes the banquet hall and other meeting areas as well. We do have one pet-friendly cabin.

“What color linens do you have for the tables?”

The Lodge has one color of napkins – white. We have two colors of tablecloths – white and chocolate brown. The white cloths are a cocktail length and are included free with any food service. If no food will be served, then they are \$4.00 each. The brown cloths are longer (not quite floor length) and rent for \$8.00 each. We also have a limited number of floor length white cloths. They rent for \$10.00 each. The brown and floor-length white cloths are not included with food service. We have pleated table skirts for our long tables. They are white only.

“Can we check into our rooms before 4:00 pm?”

Check-in time for The Lodge and Cabins is 4:00 pm. We cannot guarantee that your room will be ready until then. Check-out time is 11:00 am.

“Does The Lodge provide a minister or justice of the peace to officiate the ceremony?”

We do not have a minister or JP on-site. We can give you the number to the County Judge’s office, or you can search the yellow pages for local churches. The closest towns are Paris, Havana, Magazine, and Booneville, Arkansas.

FREQUENTLY ASKED QUESTIONS

“Can we bring in alcohol?”

Our banquet facilities operate under a private club license. Only alcoholic beverages purchased from the club are permitted in the banquet hall/conference center and restaurant. Outside beverages are not permitted. The Lodge currently sells only domestic beer and Arkansas wine. Distilled spirits are not permitted at this time.

“What if we want to serve a wine or beer that is not on The Lodge’s Wine List?”

Requests for beer or wine that The Lodge does not carry will be considered a special request. Special request items must be ordered at least 30 days prior to an event. A specific quantity must be ordered at that time (2 cases, 10 bottles, etc...). The entire amount ordered must be paid for on the day of the event. If all of the special order alcohol is not consumed by the end of the event, it cannot be taken by the guest as private club laws do not allow any alcoholic beverages to be taken from a private club.

“Can we get a keg for our event?”

At The Lodge at Mount Magazine, we sell domestic beer and Arkansas wine. Beer is sold by the bottle and wine is sold by the glass or bottle. Kegs are not permitted.

“When do I have to decide on a menu?”

A firm menu should be decided with a guest count approximately 60 days prior to an event. Changes can be made to this up until 7 days prior to an event.

“When do I have to pay my bill?”

A \$600 nonrefundable deposit is due at the time of booking. Half of your charges are due 30 days prior to your event. The remainder of your bill should be paid in full the day of the event. Alcohol charges must be paid the day of the event. A credit card number is required to hold your reservation; however you can pay by cash, check, or credit card.

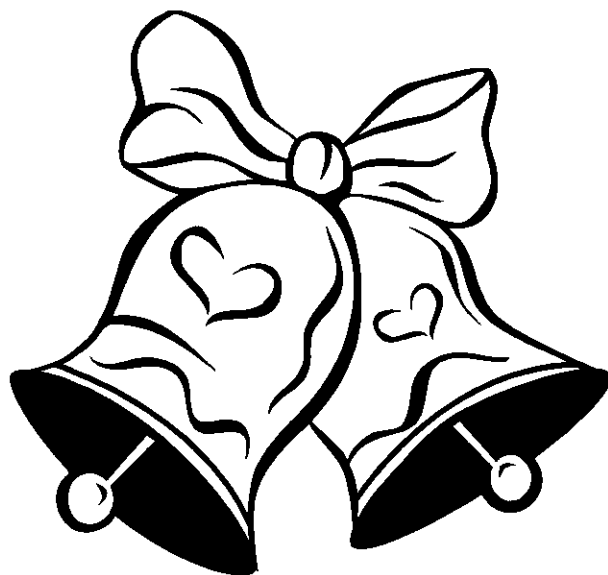

HELPFUL HINTS

Planning

- ❖ To make everything as simple as possible on the day of your wedding, hire a wedding planner/decorator to take care of all of the arrangements and decorating. This will give you and your family/friends more time to focus on you and what the day is all about.

Decorations

- ❖ Choose decorations that can easily be stored in your guestroom or vehicle.
- ❖ Have centerpieces and other decorations pre-assembled before arrival if possible. This will save you set-up time on the day of the wedding.
- ❖ Have any flowers delivered the day of the wedding – not the day before. We can store them, but our coolers are not designed for flowers, and the flowers could wilt overnight.

Food

- ❖ Think about what time of day your wedding will be. If your guests will be traveling or attending the wedding during meal time, you should serve a full meal or heavy appetizers substantial enough to satisfy your guests.
- ❖ Make sure to order enough food for everyone. If you are unsure about the quantity needed, our restaurant staff will be glad to help you.

Set-up

- ❖ Make sure you plan on enough seating for all of your guests. Our tables seat 8.

HELPFUL HINTS

Set-up, continued

- ❖ If you are not planning on serving a full meal, you may not want to have a head table. It will be empty most of the evening.
- ❖ Pick a central area in the room for your back-up ceremony location. If it rains, the ceremony will be held in the reception room, and your guests will sit at the reception tables.
- ❖ If you would like smaller tables for your cakes, or cocktail style tables, you will need to rent them elsewhere and bring them with you.

Cake

- ❖ Have your cake delivered the day of the wedding – not the day before. We can store the cake for you, but our coolers are not designed for cakes and the moisture could cause the icing to run.
- ❖ Insist that the cake be delivered in separate tiers and assembled on-site. Do not attempt to bring a cake up the mountain already assembled. There are too many corners to maneuver around and assembled cakes fall very easily.

Getting Ready

- ❖ There is not a bridal room or powder room for dressing. You should rent a guestroom the night before the wedding and the night of the wedding for this purpose. If you rent a room for just the night of the wedding, you may not have access to it until 4:00pm, our guaranteed check-in time. If you rent a room for the night before the wedding only, you will be required to check-out at 11:00 am.
- ❖ Bring extra mirrors with you. If several people will be getting ready in one room, there are only 2 mirrors in the rooms, so extra ones will be helpful.



THE LODGE
at Mount Magazine

CATERING MENU AND EVENT POLICIES

General Policies and Procedures It is the responsibility of the group leader/contact person to notify all of the group's members of The Lodge's policies. The group representative or individual authorizing the event will be responsible, and shall reimburse The Lodge, for any damages, loss, or liability incurred by any of the customer's guests or any persons or organizations contracted by the customer to provide any service or goods before, during or after the function. Mount Magazine State Park Lodge, Conference Center and cabins are smoke free and pet free environments. The lodge is not responsible for damage to, or loss of, any items left in the lodging facilities prior to or following any function.

Guarantees It is necessary that the guaranteed number of guests be confirmed one week (7 days) prior to the event. Once a guarantee is given, it may be reduced by 10% two days (48 hours) before the event; however, we can accommodate a reasonable increase. If we do not receive your guaranteed number of guests by the above time, we will use your highest expected attendance number as the guaranteed number. Final charges will be based on the guarantee or the actual attendance, whichever is higher.

Meeting Space Banquet, meeting and social rooms are assigned based on the expected attendance and activity. The Lodge reserves the right to change the room assignment. The Sparrow and Tanager meeting rooms must be vacated by 10:00pm for quiet hours as they are located near the guest quarters. The banquet hall/conference center must be vacated by 12:00

am midnight. Failure to do so may result in an additional charge to be added to the group's bill. Groups wishing to store decorating items the day prior to an event or those who want to decorate the day prior to the event must pay the full rental price for the previous day as well as the day of the event. Changes to the room set-up agreed upon by the group leader and The Lodge must be given 48 hours in advance. If a group requests a change less than 48 hours prior to a function, a \$100.00 set-up fee may be charged to the group's account.

Chairs White outdoor folding chairs are available for the Terrace and Patio areas. Chairs for these areas must be rented from The Lodge and cannot be rented from an outside vendor. Chairs are included in the rental fee for the banquet hall/conference center and meeting rooms.

Deposit and Payment Functions will be subject to a \$600.00 deposit and prepayment specifications. All major credit cards are accepted for billing purposes. Arkansas state taxes are applicable.

Decorations & Signage Decorations (including craft items) may be brought into the lodge based on prior approval from management. The Lodge does not permit affixing of any materials to walls, floors, ceilings, tables, chairs or whiteboards with staples, tape, thumbtacks, adhesive strips, glue, glue dots, sticky-tack or nails. Fog machines, confetti, popcorn, crepe paper, bubbles, rice, silly string, sparklers and sequins are prohibited. For outdoor wedding ceremonies, artificial flower petals may not be used – only real petals may be used. Any outdoor decorations, including flower petals, must be cleaned up by the group in a timely manner. Decorations must be approved prior to use. A fee will be assessed in the event of noncompliance. Signage, displays and banners brought into The Lodge must be pre-approved. Signage must be of a professional nature and is restricted to certain areas. The Lodge will assist with placement. All decorations and removal / clean-up of decorations will be the responsibility of the organization or individual scheduling the event. Decorating plans must be submitted two weeks prior to the event and approved by the Director of Sales and/or Assistant Director of Sales. Failure to comply will result in an additional service charge.

Food and Beverage No food or beverage of any kind (with the exception of wedding/celebration cakes and select bags of hard candy) will be permitted to be brought into The Lodge by any customer. Exceptions must be agreed upon in writing before being brought on-site. This does not include individually purchased items from the gift shop or vending areas. Failure to comply will result in the addition of a \$400 catering charge to the final bill. Our Chefs and kitchen staff take pride in the quality of food service. We cannot be responsible for the quality of the food served if there is a delay in the serving schedule. Please schedule your event within practical timelines. Sufficient quantities of food will be prepared and provided for all guests. However, private buffets are not "all-you-can-eat" and carryout from buffet lines is not permitted. Carry-outs are only permitted if a specific quantity is purchased (example: 2 dozen cookies, 10# of chicken tenders) and not all of the food is consumed. Food service will end at 10:00 pm. At this time, all food items will be removed from the serving area. A 20% service charge and applicable taxes will be applied to food, beverage and event services.

Allergies Please notify The Lodge sales staff of any allergies or special dietary needs for your guests no later than one week (7 days) prior to your event. Additional fees may apply.

Restaurant Our restaurant, The Skycrest, is open daily and offers a full range of menu items. We do not take reservation in the restaurant. Seating is on a first-come first-serve basis.

Smoking The Lodge at Mount Magazine is a non-smoking facility. The group is responsible for a \$200 per room cleaning fee for guests registered to the group who smoke in the guest quarters or any other area of The Lodge.

Alcohol

The Skycrest Restaurant and banquet facilities operate under a private club license. Only alcoholic beverages purchased from the club are permitted in the banquet hall/conference center and restaurant. Outside beverages are not permitted. Bar service at any event will end at 11:00 pm. All purchases of alcoholic beverages **must** be paid for on the same day as the event. Alcoholic beverages must stay inside the restaurant and conference center/banquet hall. A 20% service charge will be added to the total amount of alcohol sold for a host bar. A bartender fee of \$25.00 per hour will be charged for a cash bar.

The Skycrest Restaurant and banquet facilities serve only beer and wine. No hard liquor is permitted. Current ID will be required for each guest requesting service. A bartender is required at any event where alcohol will be served.

Audio/Visual Equipment A/V equipment may be ordered through the group sales department. We ask that all requests are made 30-45 days prior to group check-in. The Lodge at Mount Magazine will not handle, transport, store or be responsible for audio/visual equipment not rented through the lodge.

Deliveries of Materials Any materials sent to The Lodge must be appropriately labeled and addressed to ensure deliveries are not refused and to ensure materials are available when required. Please ship materials to arrive no sooner than 48 hours prior to the check in date. The Lodge at Mount Magazine does not accept liability for equipment, goods, displays, or other materials which arrive or fail to arrive at the lodge. Your group is responsible for postage, freight and insuring its property for loss or damage.

Please address shipments to:

Hold for Arrival of (guest name or onsite contact name)
Your Organization, Date of Event
c/o The Lodge at Mount Magazine
577 Lodge Drive
Paris, AR 72855

Entertainment and Outside Vendors The Lodge at Mount Magazine must be notified of all entertainment and outside vendors for events. A copy of all outside vendor contracts must be supplied to The Lodge. All vendors must check in with the front desk upon arrival. The Lodge reserves the right to regulate the volume of any entertainment in our event spaces. All vendors intending to sell items must submit a 'Special Events Permit (ACT 370 OF 1995 requires all Promoters and Organizers of Special Events to register for a reporting number to collect and report sales tax) at least 60 days prior to the event. This permit must be approved by Arkansas Department of Parks and Tourism, Division of State Parks prior to the event.

Security The Lodge at Mount Magazine does not assume liability for damage to, or loss of, equipment or personal belongings brought into The Lodge. Your organization acknowledges that The Lodge at Mount Magazine cannot be responsible for the safekeeping of equipment, supplies, written materials or other property left in function rooms. Accordingly, your group acknowledges that it is responsible for providing security of any such property, and hereby assumes the responsibility for loss thereof.

Management Right The Lodge at Mount Magazine reserves the right to cancel any function deemed by the management to reflect poorly on the integrity or safety of its staff and other guests of The Lodge.

Contracts & Billing Events will not proceed without signed and returned Event Contracts, Banquet Event Orders, Meeting and Banquet Policies, and fulfilled billing payment requirements per the contracts. All signed documents are legally binding.

The catering prices listed on our catering menu are current. However, due to market conditions, these prices are subject to change without notice. A price will be confirmed with you 30 days prior to your event with subsequent changes occurring only under extreme market conditions. Prices do not include 7% Food Tax or 20% Service Charge.

~BAKED GOODS~

Cinnamon Rolls (per dozen) May be cut into halves upon request	\$16.00
Assorted Muffins (per dozen)	\$16.00
Croissants (per dozen) Served with butter and jelly	\$22.00
Brownies (per dozen)	\$12.00
Assorted Cookies (per dozen)	\$12.00
Assorted Bagels (per dozen) Served with cream cheese	\$24.00
Soft Baked Pretzels (per dozen)	\$15.00

~SNACK ITEMS~

Assorted Granola Bars (per item)	\$1.00
Pretzels (per pound)	\$5.00
Mixed Nuts (per pound)	\$20.00
Snack Mix (per pound)	\$10.00
Salsa with Tortilla Chips (per quart)	\$8.00

-BEVERAGES-

Coffee

Regular & Decaf)

- Per pot (10 servings) **\$15.00**
- Per urn (50 servings) **\$60.00**

Iced Tea

Sweet & Unsweet

- Per pitcher (10 servings) **\$15.00**
- (Per urn (50 servings) **\$60.00**

Punch

Per Gallon (30 servings) **\$25.00**
Sparkling or Traditional Red-4 oz servings

Lemonade

2 gallons (30 servings -8 oz servings) **\$25.00**

Canned Soda

Per can

Coke, Diet Coke, Sprite, Mr. Pibb **\$1.50**

Juice

By the pitcher (serves 10) **\$15.00**
Choice of Orange, Apple, Cranberry or V8



~BREAKFAST~

Skycrest Breakfast Buffet

\$10.95

(50 person minimum for public dining)

Public dining in the Skycrest Restaurant with scrambled eggs, bacon, country sausage, hash browns, buttermilk biscuits with cream gravy, cereal, milk, juice, and coffee.

Catered Breakfast Buffet

\$10.95

(50 person minimum for private dining)

Scrambled eggs, crisp bacon, country sausage, hash browns, and buttermilk biscuits with cream gravy, orange juice, and coffee.

Catered Continental Breakfast

\$6.95

(15 person minimum for private dining; 1 hour service)

Assorted muffins, French toast, bagels with cream cheese, butter and jelly, cinnamon rolls, coffee and assorted juices.

~HORS D'OUVRES~

Cheese Log

\$17

(Per pound) Serves 12

Served with assorted crackers

Silver Dollar Sandwiches

\$30

Per Dozen

An assortment of sandwiches with ham and turkey and vegetable fillings

Pinwheels

\$75

(Per 50)

Flour tortillas rolled with cream cheese and your choice of:

- Ham
- Turkey
- Roast Beef
- Veggie
- Assortment of the above

hors d'oeuvres, continued

Dips

\$32

(Per quart) Serves 25

Served with homemade potato chips

- Spinach and Artichoke Dip – *creamy warm dip with spinach and artichoke hearts*
- Crab Dip – *warm dip with crab and creamy parmesan*
- White Queso Dip – *warm blend of cheeses and seasonings*
- French Onion Dip – *chilled sour cream, roasted onions, herbs and seasonings*
- Ranch Dip – *creamy dip with ranch seasonings*

Vegetable Tray with Dip

\$75

(Serves approximately 50 persons)

Assorted seasonal vegetables with a Ranch-style dipping sauce

Cheese Tray

\$100

(Serves approximately 50 persons)

Cheddar, Pepper Jack and Swiss cheeses served with a variety of crackers

Fresh Fruit Tray

\$150

(Serves approximately 50 persons)

Assorted fresh fruits served with a sweet creamy yogurt dip

Fruit and Cheese Tray

\$100

(Serves approximately 50 persons)

Fresh fruits with assorted cheeses served with assorted crackers and yogurt dip

Fruit, Vegetable, and Cheese Table Top Display **\$500**

(Serves approximately 150 persons)

Fruits, vegetables, and assorted cheeses displayed on a large round table, served with assorted crackers, yogurt dip, and ranch-style dip

hors d'oeuvres, continued:

Deli Tray **\$225**

(Serves approximately 50 persons)

Assorted meats, cheeses, rolls, mayonnaise and mustard

Shrimp Cocktail Ice Bowl Display **\$250**

(Approximately 7 ½ lbs.) Serves 75

Peeled Shrimp in an ice bowl display served with cocktail sauce, remoulade sauce, and lemon wedges.

Chicken Breast Strips **\$11**

(Per pound) Serves 10

Breaded and fried, served with honey mustard and ranch dipping sauces

Meatballs **\$75**

(Per 50)

In our house made Marinara Sauce

Cocktail Sausages **\$8**

(Per pound)

Cocktail sausages served in a tangy mustard grape sauce

Honey Mustard Chicken Skewers **\$25**

(Per dozen)

Stuffed Mushrooms **\$28**

(Per 25)

Mushrooms are filled with Italian sausage, zucchini, green onion, and parmesan cheese.

Chocolate Covered Strawberries **\$31**

(Per 25)

Fresh ripe strawberries, dipped in luscious milk and dark chocolate.

~CARVING STATIONS~

Carving stations include one uniformed carver for a maximum of two hours and include rolls and condiments. Carving stations may be added to a buffet or hors d'oeuvre menu, but should not be substituted for a meal.

(Per Person – 25 per minimum)

Beef Brisket	\$8 per person
Smoked Boneless Pit Ham	\$6 per person
Prime Rib	\$12 per person
Stuffed Pork Loin	\$5 per person
Turkey Breast	\$6 per person

~LUNCHEONS~

List prices are per person. Water & tea are included unless indicated otherwise. Luncheons are served with your choice of: French fries, homemade potato chips or coleslaw. Multiple selections are not permitted. Special Dietary requests will be accommodated at an additional charge. A garden salad may be served for an additional \$2.00

Char-Grilled Mountain Burger **\$8.50**

Charbroiled ground beef on a sesame seed bun served with lettuce, onion, tomato, a dill pickle spear and your choice of one side. Condiments are served on the side.

Char-Grilled Mountain Cheese Burger **\$9.75**

Charbroiled ground beef on a sesame seed bun served with cheese, lettuce, onion, tomato, a dill pickle spear and your choice of one side. Condiments are served on the side.

B.L.T. **\$7.50**

Grilled Texas toast piled high with crispy bacon, crisp lettuce, fresh tomatoes, mayonnaise, a pickle spear and your choice of one side.

Luncheons, continued:

BBQ Pork Sandwich

\$7.50

Pulled smoked pork on a sesame seed bun served with coleslaw, a pickle spear and your choice of one side.

Grilled Chicken Caesar Salad

\$10.50

Sliced grilled chicken breast served over a bed of Romaine lettuce, croutons, Parmesan cheese and Caesar dressing.

Ham & Cheese Croissant

\$9.50

Ham and Cheese served on a flaky croissant served with a pickle spear and your choice of one side.

Box Lunch

\$14.00

Includes choice of a Turkey & Cheddar or Ham & Cheddar Croissant (or an assortment) served with potato chips, cookie and canned soda or bottled water. Each served in convenient individual containers.

Plated Working Lunch

\$14.00

Includes choice of one sandwich: Grilled Chicken, Ham & Cheese Croissant, or B.L.T., cookie, canned soda or bottled water, and your choice of one side. Plated and delivered to your meeting room.

Fried Catfish

\$10.50

Catfish filets, hand tossed in cornmeal breading and fried, served with coleslaw, hushpuppies and choice of one side.

Country Fried Chicken

\$11.50

Hand breaded "chicken fried" chicken, finished with a peppered cream gravy, served with mashed potatoes and seasoned whole green beans.

Grilled Breast of Chicken

\$11.50

Marinated grilled chicken breast served with twice baked mashed potatoes and seasoned roasted mixed vegetables.

-PLATED DINNER ENTREES-

List prices are per person. Unless otherwise indicated, entrees are served with choice of two accompaniments, fresh garden salad, hot rolls with butter, coffee, iced tea and water. Multiple selections are not permitted. Special Dietary requests will be accommodated at an additional charge.

Seafood

- Catfish** **\$13.50**
Deep fried catfish filets hand tossed in our cornmeal breading, served with hushpuppies and a choice of two sides.
- Shrimp Dinner** **\$18.50**
Succulent tail-on shrimp, breaded and fried, or sautéed in a rich garlic herb butter sauce, served with choice of two sides.
- Grilled Salmon** **\$16.50**
An eight ounce grilled salmon steak, served with choice of two sides

Chicken

- Grilled Breast of Chicken** **\$11.50**
Marinated grilled chicken breast, served with choice of two sides.
- Chicken Roulade** **\$12.00**
Chicken breast stuffed with spinach and topped with a creamy cheese sauce.
- Southern Fried Chicken** **\$11.50**
Hand breaded and fried, served with choice of two sides.
- Country Fried Chicken** **\$11.50**
Hand breaded "chicken fried" chicken breast, finished with a peppered cream gravy served with choice of two sides

Plated Dinner Entrees, continued:

Beef

Prime Rib

\$27.50

(40 person minimum)

Eight ounce roasted prime rib cooked to medium, served with horseradish sauce and choice of two sides.

Beef Tenderloin Medallions

\$28.00

Beef Tenderloin Medallions topped with a rich demi-glace.

Pork

Stuffed Pork Loin

\$12.50

Pork Loin stuffed with creamed spinach and topped with a white wine cheese sauce, served with choice of two sides.

Grilled Pork Tenderloin

\$14.00

Grilled pork tenderloin with a Honey-Mustard Sauce, served with a choice of two sides.

Smoked Boneless Pit Ham

\$11.50

Smoked Boneless Pit Ham sliced and topped with a Honey Horseradish sauce, served with choice of two sides.

Pasta

Fettuccini Alfredo

\$11.50

A bed of Fettuccini noodles topped with a creamy garlic Alfredo sauce and your choice of sliced Grilled Chicken Breast or Grilled Shrimp, served with roasted vegetables and buttery toasted garlic bread.

Classic Lasagna

\$13.50

Baked layers of lasagna noodles, cheeses, and a rich meat sauce blanketed with mozzarella, served with roasted mixed vegetables and buttery toasted garlic bread.

Plated Dinner Entrees, continued:

~SIDES~

Seasoned Whole Green Beans
Seasoned Roasted Mixed Vegetables
Steamed Broccoli and Cauliflower Florets
Baked Potato with Butter & Sour Cream
Twice Baked Mashed Potatoes
Mashed Potatoes with Gravy
Mashed Sweet Potatoes

~BUFFETS~

Buffets require a minimum of 50 guests. List prices are per person.

All buffets include iced tea, ice water, and coffee as well as a choice of one dessert. Special Dietary requests will be accommodated at an additional charge.

Soup, Salad & Sandwich Buffet

\$15.00

Full salad bar with Caesar and garden salads, sliced deli meats, assorted cheeses and breads, condiments and choice of soup from broccoli & cheese, vegetable beef or potato.

Fish & Chicken Buffet

\$18.00

Dinner salad, Southern fried catfish and choice of grilled chicken breast or fried chicken strips, sweet corn in butter sauce, twice baked mashed potatoes, oven baked beans, hushpuppies, and hot rolls.

Shrimp & Catfish Buffet

\$20.00

Dinner salad, Southern fried catfish, breaded and fried shrimp, coleslaw, twice baked mashed potatoes, sweet corn in butter sauce, hushpuppies, and cornbread.

BBQ Buffet

\$20.00

Dinner salad, Choice of two meats: pork ribs, beef brisket, or chicken, baked beans, sweet corn in butter sauce, potato salad, coleslaw, and hot rolls.

Buffets, continued:

Italian Buffet

\$18.00

Caesar salad, spaghetti with meat sauce, chicken Alfredo, lasagna, roasted mixed vegetables, and garlic bread.

Home-Style Buffet

\$18.00

Dinner salad, sliced roast beef with gravy, fried chicken, mashed potatoes, green beans, corn on the cob in a butter sauce and hot rolls.

Fish & Ribs Buffet

\$20.00

Dinner salad, Southern fried catfish, BBQ pork ribs, sweet corn in butter sauce, twice baked mashed potatoes, oven baked beans, hushpuppies and hot rolls.

Holiday Buffet

\$20.00

Dinner Salad, Oven roasted turkey, smoked boneless Pit Ham, cornbread dressing, creamy mashed potatoes, roasted brown and giblet gravy, seasoned whole green beans, mashed sweet potato, cranberry sauce, and hot rolls.

~DESSERTS~

Cobbler

\$3.95 per serving

Homemade blueberry or peach cobbler

Peanut Butter Pie

\$4.95 per slice

Rich peanut butter and cream cheese in a graham cracker crust, topped with whipped cream, drizzled with chocolate sauce, and sprinkled with Butterfinger topping.

Possum Pie

\$4.95 per slice

Chocolaty cream cheese filling crust, topped with whipped cream and chocolate sauce.

Bread Pudding

\$3.95 per serving

Southern Style Bread Pudding with a glaze sauce.

Apple Dumplings

\$3.95 per serving

A whole apple that has been peeled a cored and stuffed with a cinnamon sugar filling, baked in a pastry crust and topped with a cinnamon glaze.

-CHILDREN'S MENU-

List prices are per child.

Menu items are available for children 12 and under and served with lemonade or iced tea and water. Special Dietary requests will be accommodated at an additional charge.

- | | |
|--|----------------|
| Chicken Strips | \$5.00 |
| Three golden fried strips of chicken served with Ranch dressing and French fries. | |
| Cub Burger | \$6.00 |
| Charbroiled ground beef with lettuce tomato, and onion served with French fries and a dill pickle spear. | |
| Cub Cheese Burger | \$7.25 |
| Charbroiled ground beef with lettuce tomato, and onion served with French fries and a dill pickle spear. | |
| Grilled Cheese Sandwich | \$5.00 |
| American cheese on Texas toast served with French fries and a dill pickle spear. | |
| Skycrest or Catered Breakfast Buffet | \$6.00 |
| Child's Lunch or Dinner Buffet | \$10.00 |

*The Lodge at Mount Magazine-revised April 2011
All Catering charges are subject to a 20% service charge and 7% tax.*

SKYCREST PRIVATE CLUB POLICIES

- ◆ The *Skycrest Restaurant* and banquet/conference facilities operate under a private club license. Only alcoholic beverages purchased from the club are permitted in the banquet hall/conference center and restaurant. Outside beverages are not permitted.
- ◆ A private club membership (free membership) is required by at least one guest in each party. Memberships expire 1 year from the date of issue.
- ◆ All guests drinking alcohol must be at least 21 years of age. Identification is required.
- ◆ Bar service at any event will end at 11:00 pm.
- ◆ All purchases of alcoholic beverages must be paid for on the same day as the event.
- ◆ Alcoholic beverages cannot be taken out of the restaurant and/or conference center/banquet hall.
- ◆ A 20% service charge will be added to the total amount of alcohol sold for a host bar. A bartender fee of \$25.00 per hour will be charged for a cash bar.
- ◆ A bartender is required at any private function where alcohol is being served. Alcohol will not be served in the conference center/banquet area unless a host or cash bar has been pre-arranged with the Sales and Catering Department. If the group leader does not want a bar, any guests wanting alcohol during the event must go to the restaurant to place their order.
- ◆ The Skycrest Restaurant and banquet facilities serve only beer and wine. No distilled liquor is permitted.
- ◆ A request for beer or wine that The Lodge does not carry is considered a special request. If a special request is made, a specific quantity must be ordered (2 cases, 10 bottles, etc). The entire amount ordered must be paid for on the day of the event. If all of the special order alcohol is not consumed by the end of the event, it cannot be taken by the guest as private club laws do not allow any alcoholic beverages to be taken from a private club.

BANQUET BEVERAGE MENU

~WINE~

<u>WHITE</u>	<u>BOTTLE</u>	<u>GLASS</u>
Post Vidal Blanc	\$17.00	
Post Chardonnay	\$19.00	
Ecco Domani Pinot Grigio.....	\$27.00	
Domaine Montel Sauvignon Blanc	\$23.00	
Vendange Chardonnay	n/a	\$5.00
La Villa Pinot Grigio		\$6.00
 <u>BLUSH</u>		
Post Blush Muscadine	\$19.00	
Post White Zinfandel.....	\$18.00	
Domaine Montel White Zinfandel.....	\$23.00	
Vendange White Zinfandel.....	n/a	\$5.00
 <u>RED</u>		
Post Red Zinfandel.....	\$17.00	
Post Merlot.....	\$31.00	
Domaine Montel Cabernet.....	\$23.00	
Domaine Montel Merlot	\$23.00	
Domaine Montel Syrah.....	\$23.00	
Wiederkehr Beau Noir	\$17.00	
Vendange Cabernet.....	n/a	\$5.00
Vendange Merlot	n/a	\$5.00
 <u>SPARKLING</u>		
Ballatore Gran Spumante.....	\$25.00	

~BEER~

DOMESTIC - \$2.50 per bottle

Budweiser, Bud Light, Miller Lite, and Coors Light

PREMIUM BEERS

Michelob Ultra - \$3.00 per bottle

Samuel Adams Boston Lager - \$3.50 per bottle

SAVING THE DATE

Please call our Group Sales Department at 1-877-MM-LODGE
(1-877-665-6343)

It is recommended to call at least 12 months in advance to ensure that the date you choose is available.

When calling to make a reservation, please provide the following information:

- ◇ Bride's and Groom's Name
 - ◇ Contact Information
 - ◇ Date and Time of Event
- ◇ Estimated Beginning and Ending Times of Event
 - ◇ Choice of Location
 - ◇ Approximate Guest Count
- ◇ Style of Event (formal, informal, buffet, etc.)

A \$600.00 deposit and a valid credit card number are required at the time of booking.

We require signed copies of a booking agreement, function contract, and meeting and banquet policy to secure the function space for your event.

